

Technical Data

Specifications & Capacities

120|RT

Telescopic Boom Rough Terrain Crane

120 US ton

110 metric ton

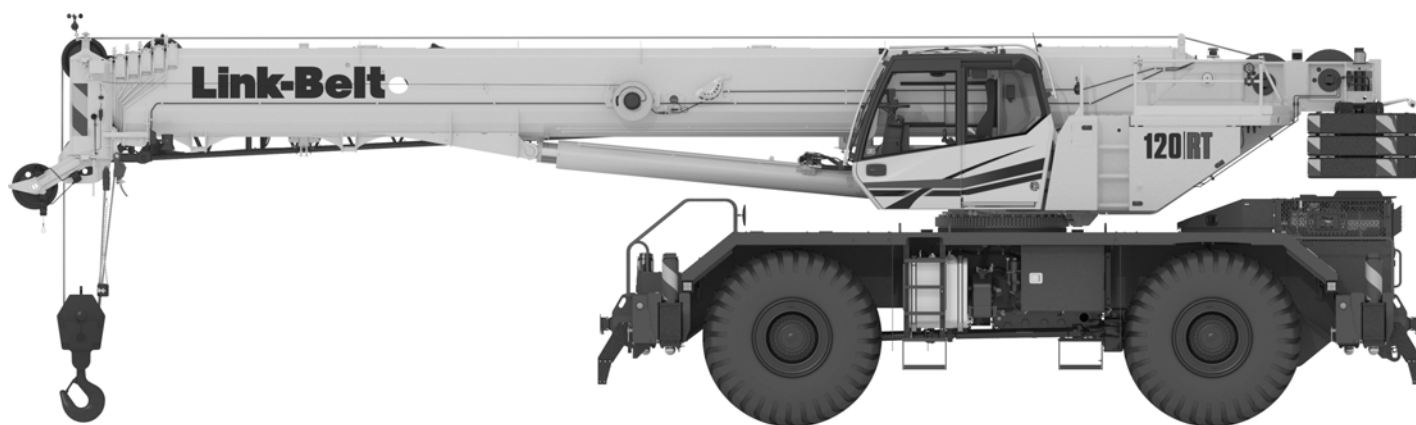

CAUTION: This material is supplied for reference use only. Operator must refer to in-cab Crane Rating Manual and Operator's Manual to determine allowable crane lifting capacities and assembly and operating procedures.

Table Of Contents

Boom, Attachments, and Upper Structure	1
Boom	1
Boom	1
Boom Wear Pads	1
Boom Head	1
Boom Elevation	1
Auxiliary Lifting Sheave	1
Hook Blocks and Balls – Optional	1
Fly – Optional	1
Fly Extensions – Optional	1
Fly Controls	1
Operator’s Cab and Controls	1
Swing	3
Electrical	3
Load Hoist System	3
Load Hoist Performance	3
Main and Auxiliary Winches	3
Hydraulic System	3
Counterweight	3
Carrier	4
General	4
Outriggers	4
Steering and Axles	4
Suspension	4
Tires and Wheels	4
Brakes	4
Electrical	4
Engine	4
Transmission	4
Fuel Tank	5
Hydraulic System	5
Pump Drive	5
Maximum Speed	5
Paint	5
Additional Equipment Options	5
Gradeability	5
Axle Loads	5
General Dimensions	6
Working Range Diagram	7
Main Boom	7
Working Range Diagram	8
Main Boom + Fly	8
Boom Extend Modes	9
Main Boom Lift Capacity Charts – Imperial	10
28,800 lb Counterweight – Fully Extended Outriggers – 360° Rotation	10

Fly Attachment Lift Capacity Charts – Optional	11
28,800 lb Counterweight – Fully Extended Outriggers – 360° Rotation	11
164.1 ft Main Boom Length	11
28,800 lb Counterweight – Fully Extended Outriggers – 360° Rotation	12
164.1 ft Main Boom Length	12
Main Boom Lift Capacity Charts – On Tires	13
28,800 lb Counterweight – On Tires – Stationary – Boom Centered Over Front Between Tire Tracks	13
28,800 lb Counterweight – On Tires – Pick & Carry (Creep) – Boom Centered Over Front	14
28,800 lb Counterweight – On Tires – Pick & Carry (2.5 mph) – Boom Centered Over Front	15
Main Boom Lift Capacity Charts – 85% – Metric	16
13.2t Counterweight – Fully Extended Outriggers – 360° Rotation	16
Fly Attachment Lift Capacity Charts – Optional	17
13.2t Counterweight – Fully Extended Outriggers – 360° Rotation	17
50.02m Main Boom Length	17
13.2t Counterweight – Fully Extended Outriggers – 360° Rotation	18
50.02m Main Boom Length	18
Main Boom Lift Capacity Charts – On Tires	19
13.2t lb Counterweight – On Tires – Stationary – Boom Centered Over Front Between Tire Tracks ..	19
13.2t lb Counterweight – On Tires – Pick & Carry (Creep) – Boom Centered Over Front	20
13.2t Counterweight – On Tires – Pick & Carry 4 kph) – Boom Centered Over Front	21

Boom, Attachments, and Upper Structure

■ Boom

Design — Six section, formed construction of extra high tensile steel consisting of one base section and five telescoping sections. The two plate design of each section has multiple longitudinal bends for superior strength. Each telescoping section extends independently by means of one double-acting, single stage hydraulic cylinder with integrated holding valves.

Boom

- 38.3–164.1 ft (11.67–50.0m) six section boom
- Four boom extend modes (EM1 through EM4), controlled from the operator's cab, provide superior capacities by varying the extension of the telescoping sections:
 - EM1 extends to 164.1 ft (50.0m)
 - EM2 extends to 140.0 ft (42.7m)
 - EM3 extends to 114.6 ft (34.9m)
 - EM4 extends to 89.5 ft (27.3m)
- Mechanical boom angle indicator
- Maximum tip height for each extend mode is:
 - EM1 is 173.6 ft (52.9m)
 - EM2 is 150.2 ft (45.8m)
 - EM3 is 124.9 ft (38.1m)
 - EM4 is 100.2 ft (30.5m)

Boom Wear Pads

- Wear pads with Teflon inserts that self-lubricate the boom sections
- Bottom wear pads are universal for all boom sections
- Top wear pads are universal for all boom sections

Boom Head

- Five 16.5 in (41.9cm) root diameter nylon sheaves to handle up to ten parts of line
- Easily removable wire rope guards
- Rope dead end lugs on each side of the boom head
- Boom head is designed for quick-reeve of the hook block
- Wind speed indicator
- Aviation obstruction solar marking light and flag — optional

Boom Elevation

- One double acting hydraulic cylinder with integral holding valve
- Boom elevation: -3° to 80°

Auxiliary Lifting Sheave

- Single 16.5 in (41.9cm) root diameter nylon sheave
- Easily removable wire rope guards
- Does not affect erection of the fly or use of the main head sheaves

Hook Blocks and Balls — Optional

- 27 ton (25mt) 1 sheave quick-reeve hook block with safety latch
- 60 ton (55mt) 3 sheave quick-reeve hook block with safety latch
- 88 ton (80mt) 5 sheave quick-reeve hook block with safety latch
- 132 ton (120mt) 7 sheave quick-reeve hook block with safety latch
- 10 ton (9.1mt) swivel and non-swivel hook balls with safety latch

Fly — Optional

- 35–58 ft (10.7–17.7m) two piece bi-fold lattice fly, stowable, offsettable to 0° , 15° , 30° , and 45° . Maximum tip height is 230.4 ft (70.4m).

Fly Extensions — Optional

- One 16 ft (4.9m) lattice extension, to be mounted between the boom head and fly options. Maximum tip height is 246.1 ft (75.0m).
- Two 16 ft (4.9m) lattice extensions, to be mounted between the boom head and fly options. Maximum tip height is 261.7 ft (79.8m). Minimum of 19,200 lb (8.8t) of counterweight required.

Fly Controls

- One man assembly, minimizing ladder climbs
- Control box with fly assist and boom hoist cylinder switches located on front frame
- Sure-lock system prevents fly from ever being completely unpinning during assembly
- Speed screws for boom head and pivot point

■ Operator's Cab and Controls

Environmental Cab — Fully enclosed, one person cab of tubular and sheet steel structure with formed plastic interior panels.

Equipped with:

- Tinted and tempered glass windows
- Extra-large fixed front window with time delayed windshield wiper and washer
- Swing up roof window with windshield wiper and washer
- Sliding left side door with large fixed window
- Sliding right side window and pop-out rear window for ventilation
- Six way adjustable, cushioned seat with seat belt and two storage compartments
- Diesel fired warm-water heater with ten air ducts for front windshield defroster and cab floor
- Air Conditioning — Integral with cab heating system utilizing the same ventilation outlets and automatic temperature control (ATC)
- Adjustable sun screen
- Dome lights with red nighttime reading LED's
- Cup holder
- Fire extinguisher
- Two position travel swing lock
- AM/FM radio
- Tilting cab (0° – 20°)

Engine Dependent Warm—Water Heater – Optional – With air ducts for front windshield defroster and cab floor

Steering Column – Pedestal type with dual tilting functions for operator comfort. Column includes the following controls and indicators:

- Horn button
- Turn signal switch
- Driving light switch
- Transmission gear selector
- Transmission direction switches
- Travel park brake
- 2/4 wheel drive/range selector
- Hazard flasher

Armrest Controls – Two dual axis electronic joystick controllers or optional single axis electronic controllers for:

- Swing
- Boom hoist
- Main (rear) winch
- Auxiliary (front) winch
- Winch high/low speed switch(es)
- Warning horn button
- Swing park brake switch
- Engine throttle lock switch
- Engine set/resume switch
- Cab tilt
- Telescope override

Outrigger Controls – Hand held control box with umbilical cord gives the operator the freedom to view operation while setting the outriggers.

Foot Controls

- Boom telescope
- Swing brake
- Service brake
- Engine throttle

Upper Right Console – Controls and indicators for:

- Engine ignition
- Engine stop
- Function lockout
- Front windshield wiper and washer
- Cab lights and upper frame lights
- Horn
- Dome light with switch
- E—stop switch
- Radio
- DRI on/off selection
- HVAC controller
- Boom floodlights
- Rotating beacon/Strobe light
- Top hatch wiper washer
- Winch(es) disable
- Engine indicator gauge
- 360° swing lock – optional

Internal RCL Light Bar – Visually informs the operator when crane is approaching maximum load capacity with a series of green, yellow, and red lights.

Integrated Third Wrap Function Kickout – Link-Belt Pulse 2.0 color display visually and audibly warns the operator when the wire rope is on the first/bottom layer and provides a function kickout when the wire rope is down to the last three wraps.

External RCL Light Bar – **Optional** – Visually informs the ground crew when crane is approaching maximum load capacity with a series of green, yellow, and red lights.

Rear Right Side Panel

- 12V accessory outlet (10amp)
- USB charge port

Camera Display – Located on the right A—post with an adjustable mount

- Displays right side of upper
- Displays main and auxiliary winches
- Displays rear view

Diagnostic Center – Located on the right rear wall behind the seat.

- Engine diagnostic
- RCL CANBUS diagnostic
- Master controller CANBUS diagnostic

Fuse & Relay Panel – Located on the left rear wall behind the seat.

Link-Belt Pulse 2.0 – The Link-Belt in-house designed, total crane operating system that utilizes a 10 inch touch screen color display with integrated RCL and engine data, advanced diagnostics and systems monitoring, Wi-Fi capable for remote software updates, operator customizable, and a readout and operator interface for the following systems:

- **Rated capacity limiter** – LCD graphic audio – visual warning system integrated into the dash with anti – two block and function limiter. Operating data includes:
 - RCL controller USB diagnostic
 - Crane configuration
 - Boom length and angle
 - Boom head height
 - Allowed load and % of allowed load
 - RCL light bar
 - Boom angle
 - Radius of load
 - Actual load
 - Wind speed
 - Highlighted unit of measurement on working screen
 - Telescope operation displayed in real time
 - Steer mode selector
 - Outrigger position sensing
 - Drum Rotation direction indication
 - Third wrap indicator – optional
 - Diagnostics
 - Operator settable alarms with function kickout (include):
 - Maximum and minimum boom angles
 - Maximum tip height
 - Maximum boom length
 - Swing left/right positions
 - Operator defined area (imaginary plane)
- **Cab Instrumentation**
 - Speedometer
 - Tachometer
 - Engine water temperature
 - Fuel level
 - Hydraulic oil temperature
 - Stop engine
 - Check engine
 - Wait to start
 - Transmission oil temperature
 - Diesel exhaust fluid (DEF) level⁽¹⁾
 - Engine air filter high restriction light
 - Regeneration light⁽¹⁾
 - Regeneration inhibit switch⁽¹⁾
 - Regeneration initiate switch⁽¹⁾
 - High exhaust temperature light⁽¹⁾
 - Regeneration disabled light⁽¹⁾
 - Swing park brake light
 - Engine speed
 - Engine oil pressure light
 - Battery voltage
 - Fuel rate (gal/hr)
 - Engine load
 - Engine Diagnostics

⁽¹⁾ (Stage V/Tier 4F engine only)

- **Telematics** – Cellular based data logging and monitoring system that provides:
 - Location and operational settings
 - Routine maintenance
 - Crane and engine monitoring
 - Diagnostic and fault codes

■ Swing

Motor/Planetary — Bi-directional hydraulic swing motor mounted to a planetary reducer for 360° continuous smooth swing at 1.9 rpm

Swing Park Brake — 360°, electric over hydraulic, (spring applied/hydraulic released) multi-disc brake mounted on the speed reducer. Operated by a switch from the operator's cab.

Swing Brake — 360°, foot operated, speed reducing system with disc brake hold feature

Swing Lock — Two-position swing lock (boom over front or rear) operated from the operator's cab.

360° Positive Swing Lock — Optional — Meets New York City requirement

■ Electrical

Swing Alarm — Audio/video warning device signals when the upper is swinging.

Lights

- Two LED working lights on front of the cab
- Two amber strobe lights at rear of the upper frame
- LED Boom floodlight — Dual
- LED Frame work lights — right front, left rear, and work platform
- One LED working light on top of cab — optional
- Boom floodlight — High intensity remote controlled — optional
- LED electrical compartment

■ Load Hoist System

Load Hoist Performance

Main (Rear) and Auxiliary (Front) Winches — 3/4 in (19mm) Rope										
Layer	Maximum Line Pull		Normal Line Speed		High Line Speed		Layer		Total	
	lb	kN	ft/min	m/min	ft/min	m/min	ft	m	ft	m
1	23,632	105.12	167	50.9	268	81.7	115	35.1	115	35.1
2	21,616	96.15	183	55.8	293	89.3	125	38.1	240	73.2
3	19,917	88.60	198	60.4	318	96.9	136	41.5	376	114.6
4	18,465	82.14	214	65.2	343	104.5	147	44.5	522	159.1
5	17,211	76.56	229	69.8	368	112.2	157	47.9	679	207.0
6	16,116	71.69	245	74.7	393	119.8	168	51.2	847	258.2

Wire Rope Application		in	mm	Type	lb	kg
Main (Rear) Winch	Standard	3/4	19	37x7 rotation resistant — right lang lay (Type KC)	16,000	7 257.5
	Optional	3/4	19	35x7 rotation resistant — right lang lay (Type CC)	17,160	7 783.6
Auxiliary (Front) Winch	Standard	3/4	19	37x7 rotation resistant — right lang lay (Type KC)	16,000	7 257.5
	Optional	3/4	19	35x7 rotation resistant — right lang lay (Type CC)	17,160	7 783.6

Main and Auxiliary Winches

- Axial piston (2-speed) motors driven through planetary reduction unit for positive control under all load conditions.
- Grooved lagging
- Power up/down mode of operation
- Hoist drum cable follower
- Drum rotation indicator
- Drum diameter: 15 in (38.1cm)
- Rope length:
 - Main: 850 ft (259m)
 - Auxiliary: 600 ft (182.9m)
- Maximum rope storage: 850 ft (259m)
- Terminator style socket and wedge

■ Hydraulic System

Counterbalance Valves — All hoist motors, boom extend cylinders, and boom hoist cylinders are equipped with counterbalance valves to provide load lowering and prevents accidental load drop when hydraulic power is suddenly reduced.

■ Counterweight

Standard — Total of 28,800 lb (13.2t) counterweight consisting of three counterweight slabs pinned to the upper with capacities for:

- 0 lb (0t) counterweight
- 9,600 lb (4.4t) counterweight
- 19,200 lb (8.8t) counterweight
- 28,800 lb (13.2t) counterweight

Hydraulic counterweight removal activated by upper frame mounted toggle switch.

Carrier

General

- 10 ft 11 in (3.33m) wide
- 14 ft 4 in (4.37m) wheelbase (centerline of first axle to centerline of second axle)

Frame – Box–type, torsion resistant, welded construction made of high tensile steel. Equipped with front and rear towing and tie–down lugs, tow connections, and access ladders.

- Six points of access
- Flat deck
- Three lockable storage boxes

Pintle Hooks – Optional – Front and rear available

Outriggers

Boxes – Two double box, front and rear welded to carrier frame

Beams and Jacks – Four single stage beams that are hydraulically controlled from the operator's cab with integral check valves.

V–CALC – Variable confined area lifting capabilities that are incorporated directly into the Pulse 2.0 display allowing multiple outrigger configurations of fully extended, intermediate, and fully retracted, with live on screen working radii, utilizing 360° charts, and swing arrest.

Pontoons – Four lightweight, serviceable, quick release, 24 in diameter (60.96cm), steel pontoons with contact area of 452 in² (2 916cm²) can be stored for road travel in storage racks on the carrier.

Main Jack Reaction – 120,300 lb (54 567kg) force and 249 psi (1 716kPa) ground bearing pressure.

Steering and Axles

Steering – Four independent modes consisting of two wheel front, two wheel rear, four wheel, and crab. Each mode is controlled from the Pulse 2.0 display.

Drive – Two modes: 4 x 2 and 4 x 4 for off highway travel

Axle 1 – Steered, non–driven for 4 x 2 and steered, driven for 4 x 4

Axle 2 – Steered, driven

Emergency Steer System – Optional

Suspension

Front – Rigid mount to the carrier frame

Rear – The rear axle is suspended on the oscillation cylinders with motion of the axle controlled by a four bar greaseless linkage system. The oscillation cylinders lockout when the upper structure rotates 2.5° past centerline.

Hydro–gas Rear Suspension – Optional

Ride Height Adjustment – Suspension can be lowered for transport using a carrier mounted toggle switch from ground level.

Tires and Wheels

Front and Rear – Four (single) 29.5 x 25–34 ply rating, earthmover type tires on steel disc wheels

- Spare tires and wheels – optional

Brakes

Service – Full hydraulic, dual circuit, disc type brakes on all wheel ends

Parking/Emergency – Spring applied type, acting on front axle

Electrical

Two batteries provide 24 volt starting and operation

Lights (LED)

- All lights are LED.
- Front lighting includes two main headlights and two parking/directional indicators.
- Side lighting includes outrigger lights and two parking/directional indicators per side.
- Rear lighting includes two directional indicators, two parking/brake lights, and two reversing lights.
- Electrical and battery compartment lights.

Engine

Specification	Cummins QSB	
Emissions Compliance Level:	Stage V/Tier 4F ⁽¹⁾	Tier 3/Stage IIIA ⁽²⁾
Numbers of Cylinders	6	6
Cycle	4	4
Bore and Stroke: inch (mm)	4.21 x 4.88 (107 x 124)	4.21 x 4.88 (107 x 124)
Piston Displacement: in ³ (L)	408 (6.7)	408 (6.7)
Max. Brake Horsepower: hp (kW)	232 (173) @ 2,000 rpm	240 (179) @ 2,000 rpm
Peak Torque: ft lb (Nm)	700 (949) @ 1,500 rpm	728 (987) @ 1,500 rpm
Electric/starting systems: volts	24/24	24/24
Alternator: amps	140	140
Crankcase Capacity: qt (L)	15 (14.2)	15 (14.2)

- Water/fuel separator w/ heater and water in fuel (WIF) sensor
- 120–volt block heater – Stage V/Tier 4F
- 220–volt block heater – Tier 3/Stage IIIA
- Grid heater – 112 amp
- Mechanically driven, variable speed, engine controlled, viscous fan clutch
- ⁽¹⁾ Can only be sold and/or operated where Stage V/Tier 4F off–highway emission standards are accepted.
- ⁽²⁾ Can only be sold and/or operated where Tier 3/Stage IIIA off–highway emission standards are accepted.

Transmission

Powershift – Three speed with high/low range for 6 forward and 6 reverse gears. Front axle disconnect for two or four wheel drive. Front axle disconnects in high range.

■ Fuel Tank

One 75 gallon (283.9L) capacity tank

Diesel Exhaust Fluid (DEF) tank

- One 10 gal (37.9L) capacity tank

■ Hydraulic System

All functions are hydraulically powered allowing positive precise control with independent or simultaneous operation of all functions.

Main Pumps

- Two variable displacement, load sense, piston pumps with anti-stall for the boom hoist, boom extend, front winch and rear winch.
- One three section fixed displacement gear pump for the oil cooler, swing, steer, brakes, and outrigger.
- Combined pump capacity of 128 gpm (484.5Lpm)

Hydraulic Reservoir – 183 gal (692.7L) capacity equipped with sight level gauge. Diffusers built in for deaeration.

Filtration – One 5 micron, full flow return line filter.

Accessible for easy filter replacement.

Hydraulic Oil Coolers – One carrier mounted cooler removes heat from the hydraulic oil. Remote mounted on right side of the carrier.

■ Pump Drive

All pumps are mechanically driven by the diesel engine.

■ Maximum Speed

15 mph (24.14 km/h)

■ Gradeability

Counterweight	Ascending		Descending		Side	
	Degrees	% Grade	Degrees	% Grade	Degrees	% Grade
0	17.0	31%	5.0	9%	3.0	5%
9,600 lb (4.4t)	15.0	27%	14.0	25%		
19,200 lb (8.8t)	14.0	25%	14.0	25%		
28,800 lb (13.2t)	13.0	23%	13.0	23%		

Axle Loads

Base Machine Includes: two winches with cable followers, standard wire rope length, full counterweight, dual boom flood lights, auxiliary lifting sheave, two-piece fly, 60t hookblock, and 10t hookball.		Gross Vehicle Weight ⁽¹⁾		Front Axles		Rear Axles	
		lb	kg	lb	kg	lb	kg
		Stage V/Tier 4F	123,540	56 037	58,433	26 505	65,106
Stage 3A/Tier 3	122,861	55 729	58,136	26 731	64,725	29 359	
Remove	Full 28,800 lb (13.2t) Counterweight	-29,068	-13 185	10,157	4 607	-39,224	-17 791
	Two-piece Fly	-2,650	-1 202	-4,096	-1 858	1,446	656
	Auxiliary Lifting Sheave	-110	-50	-293	-133	183	83
	60t Hookblock	-1,400	-635	-2,124	-964	724	329
	10t Hookball	-580	-263	-880	-400	300	136

Tire	Maximum Allowable Axle Load @ 15 mph (24.1km/h)
29.5 x 25 (34-PR)	72,800 lb (33 021kg)

⁽¹⁾ Adjust gross vehicle weight and axle loading according to component weight.

Note: All weights are ±3%.

■ Paint

Entire machine is pre-painted and oven baked with Highsolid Paint (2 part epoxy/polyester) and/or (2 part epoxy primer/2 part polyurethane top coat). Standard Link-Belt Red, Link-Belt Gray, and Gloss Black colors apply.

■ Additional Equipment Options

- Spark arrestor (export only)
- Engine air intake shutoff valve
- Cold weather package (domestic only)
- Arctic weather package (domestic only)
- Filter kits

General Dimensions

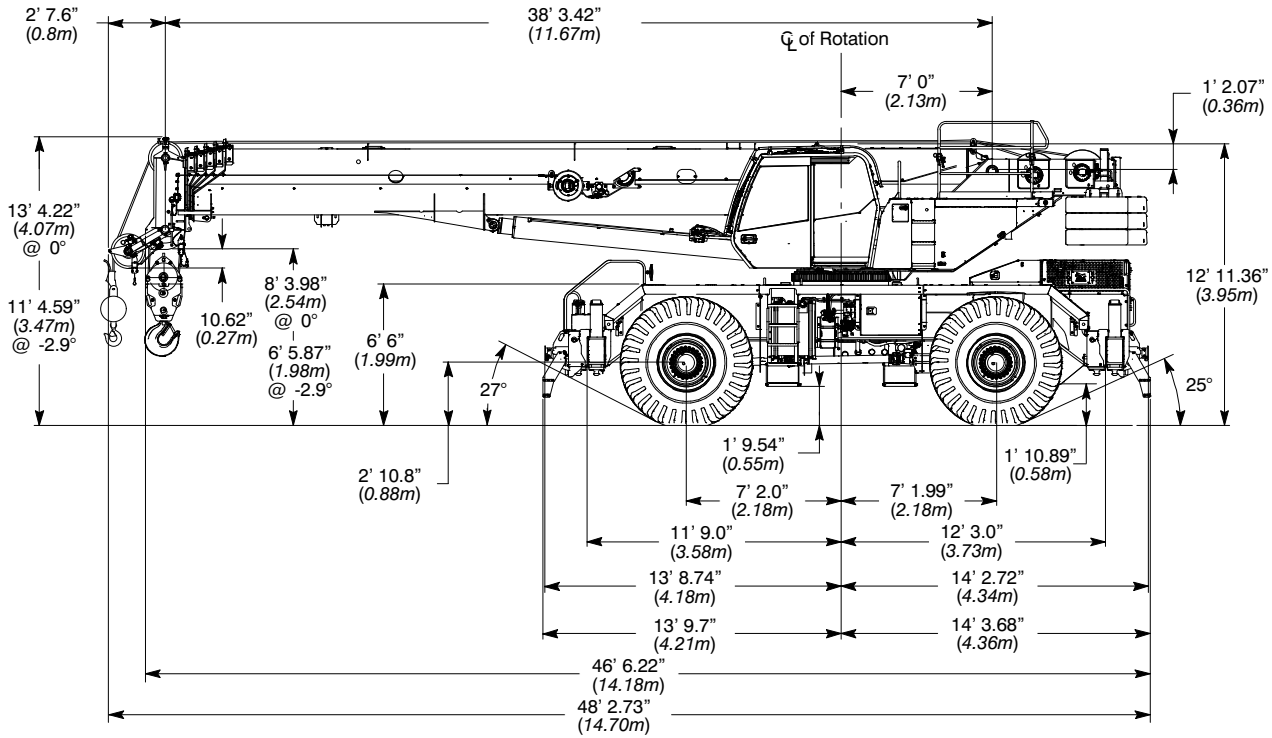

Turning Radius – Front Wheel (4x2) Steering		
	English	Metric
Wall to wall over carrier	46' 11"	14.30m
Wall to wall over boom attachment	56' 8"	17.30m
Curb to curb	45' 4"	13.80m
Centerline of tire	43' 11"	13.40m

Turning Radius – All Wheel (4x4) Steering		
	English	Metric
Wall to wall over carrier	27' 2"	8.30m
Wall to wall over boom attachment	38' 11"	11.80m
Curb to curb	25' 4"	7.70m
Centerline of tire	24' 0"	7.30m

Tail Swing		
	English	Metric
With counterweight	14' 2"	4.32m
Without counterweight	13' 0"	3.96m

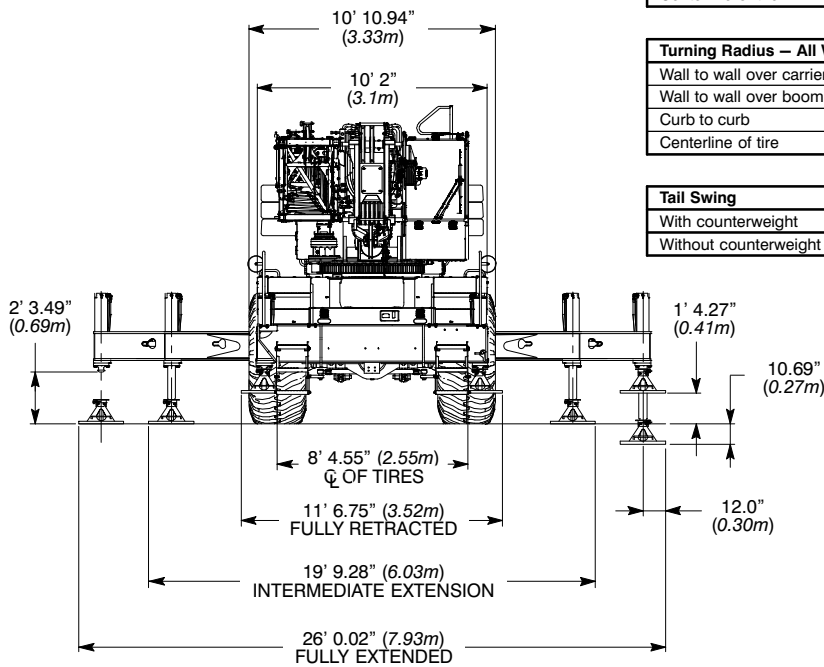

Not To Scale

Working Range Diagram Main Boom

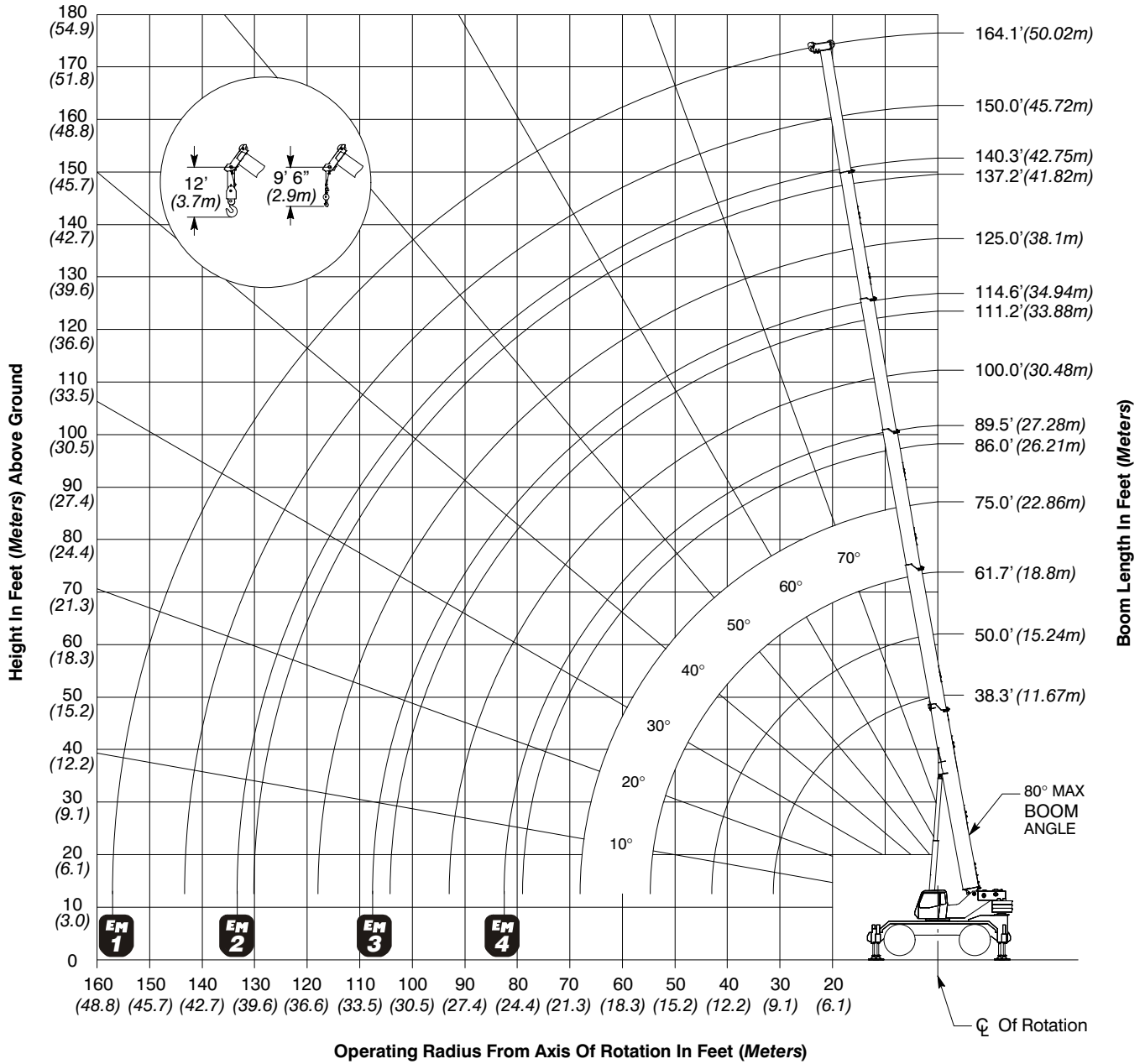

Working Range Diagram Main Boom + Fly

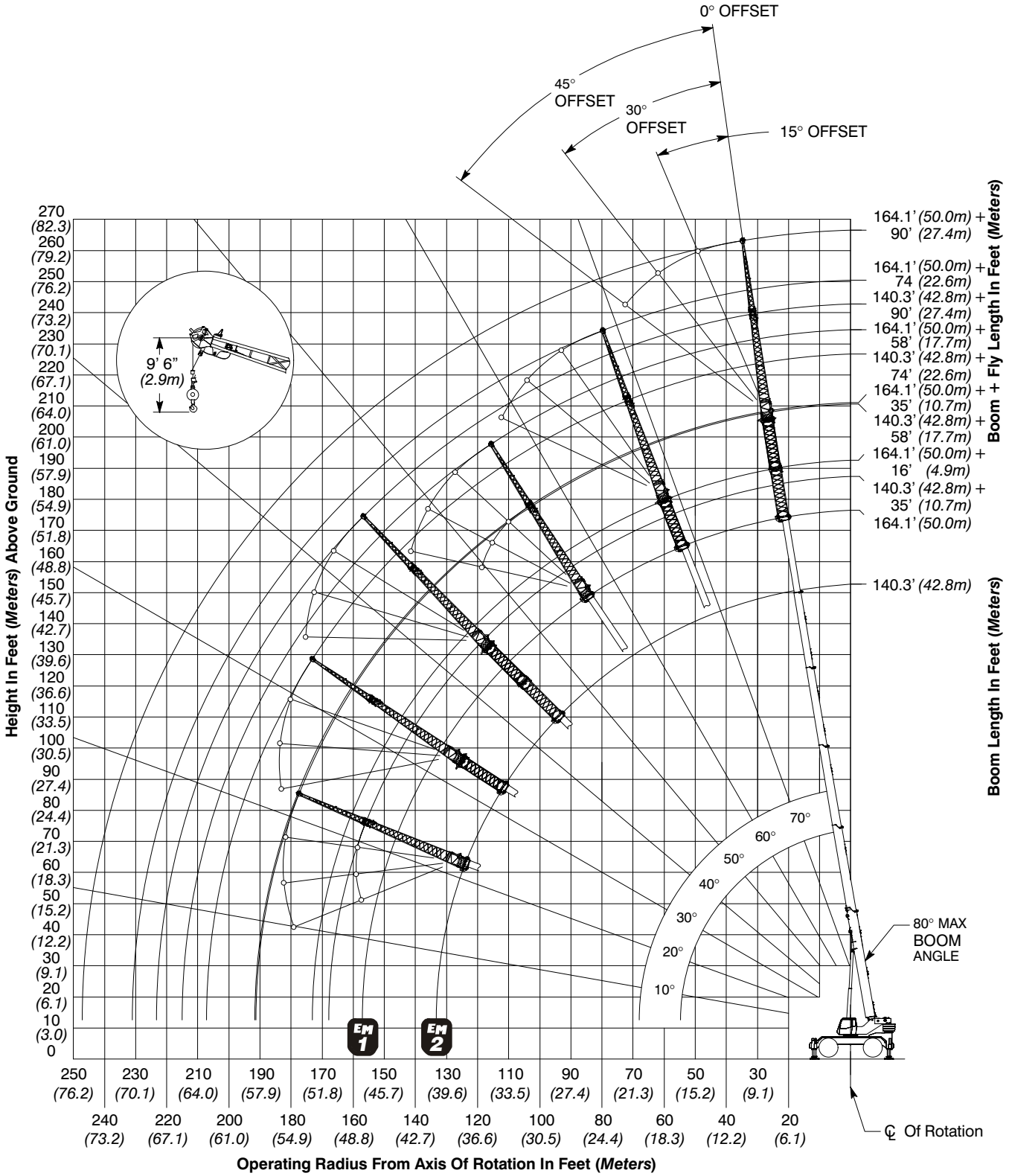

Boom Extend Modes

Boom Length		Telescope Length				
ft	m	T5	T4	T3	T2	T1
38.3	11.67					
50	15.24	50%				
61.7	18.80	100%				
75	22.86	100%	55%			
86	26.21	100%	100%			
100	30.48	100%	100%	56%		
111.2	33.88	100%	100%	100%		
125	38.10	100%	100%	100%	53%	
137.2	41.82	100%	100%	100%	100%	
150	45.72	100%	100%	100%	100%	48%
164.1	50.02	100%	100%	100%	100%	100%

Boom Length		Telescope Length				
ft	m	T5	T4	T3	T2	T1
38.3	11.67					
50	15.24	50%				
62.1	18.94	50%	50%			
75	22.86	50%	50%	51%		
87.3	26.62	50%	50%	100%		
100	30.48	50%	50%	100%	49%	
113.4	34.55	50%	50%	100%	100%	
125	38.10	50%	50%	100%	100%	43%
140.3	42.75	50%	50%	100%	100%	100%

Boom Length		Telescope Length				
ft	m	T5	T4	T3	T2	T1
38.3	11.67					
50	15.24	50%				
62.1	18.94	50%	50%			
74.7	22.78	50%	50%	50%		
87.8	26.75	50%	50%	50%	50%	
100	30.48	50%	50%	50%	50%	46%
114.6	34.94	50%	50%	50%	50%	100%

Boom Length		Telescope Length				
ft	m	T5	T4	T3	T2	T1
38.3	11.67					
50.5	15.38	0%	50%			
63	19.21	0%	50%	50%		
76.1	23.18	0%	50%	50%	50%	
89.5	27.28	0%	50%	50%	50%	50%

Main Boom Lift Capacity Charts – Imperial

28,800 lb Counterweight – Fully Extended Outriggers – 360° Rotation (All Capacities Are Listed In Pounds)												
Radius (ft)	Boom Length (ft)											Radius (ft)
	38.3	50–50.5	61.7–63	74.7–76.1	86–89.5	100	111.2–114.6	125	137.2–140.3	150	164.1	
7	240,000**											7
8	200,000*											8
10	187,400*											10
10	163,100	160,500	137,600									10
12	146,000	147,100	137,600	120,400								12
15	125,700	127,400	124,800	120,400	91,800							15
20	92,200	95,000	95,800	95,600	91,800	66,100	50,600					20
25	71,300	74,200	75,100	75,000	74,100	66,100	50,600	38,900	25,500			25
30	57,100	60,100	61,100	61,900	62,300	61,400	50,600	38,900	31,000	22,600		30
35		49,800	51,900	52,400	52,100	51,300	46,300	38,900	31,000	22,600	19,700	35
40		42,700	44,300	44,700	44,500	43,700	41,800	38,200	31,000	22,600	19,700	40
45			37,100	37,500	37,100	36,100	35,200	35,200	31,000	22,600	19,700	45
50			31,000	31,500	31,100	31,400	30,500	30,300	29,500	22,600	19,700	50
55			26,300	26,800	27,000	26,700	26,400	25,700	25,000	22,600	19,700	55
60				23,100	23,300	23,000	22,700	22,600	22,900	22,600	19,700	60
65				20,300	20,300	20,000	19,700	21,100	20,800	20,100	19,500	65
70					17,800	18,000	18,100	18,600	18,300	17,600	17,000	70
75					15,800	16,900	16,900	16,500	16,200	15,700	15,100	75
80					14,000	15,300	15,300	14,900	14,500	13,900	13,300	80
85						13,700	13,800	13,300	13,000	12,400	11,800	85
90						12,300	12,400	12,000	11,700	11,000	10,400	90
95							11,200	10,800	10,500	9,900	9,300	95
100							10,100	9,700	9,400	8,800	8,200	100
105							7,400	8,800	8,500	7,900	7,300	105
110								7,900	7,700	7,100	6,500	110
115								7,200	6,900	6,300	5,700	115
120									6,200	5,600	5,100	120
125									5,600	5,000	4,400	125
130									5,000	4,400	3,900	130
135										3,900	3,400	135
140										3,400	2,900	140
145											2,400	145
150											2,000	150
155											1,700	155

* Over Front Only With Special Reeving And/Or Special Equipment
 ** Over Front Only With Special Reeving And/Or Special Equipment On Intermediate Outriggers

This information is not for crane operation. Operator must refer to the in-cab information for crane operation. Rated lifting capacities shown on fully extended outriggers do not exceed 85% of the tipping loads and on tires do not exceed 75% of the tipping loads.

Fly Attachment Lift Capacity Charts – Optional

28,800 lb Counterweight – Fully Extended Outriggers – 360° Rotation									
164.1 ft Main Boom Length									
Radius (ft)	35 ft Manual Offset Fly				58 ft Manual Offset Fly				Radius (ft)
	0°	15°	30°	45°	0°	15°	30°	45°	
10									10
12									12
15									15
20									20
25									25
30									30
35									35
40	10,900								40
45	10,900								45
50	10,900				7,400				50
55	10,900	11,400			7,400				55
60	10,900	11,400			7,400				60
65	10,900	11,400	11,400		7,400	7,700			65
70	10,900	11,400	11,300	10,100	7,400	7,600			70
75	10,900	11,400	11,100	10,000	7,400	7,400			75
80	10,900	11,400	11,000	9,800	7,400	7,300	6,300		80
85	10,900	11,400	10,800	9,700	7,400	7,200	6,200		85
90	10,600	11,400	10,600	9,500	7,400	7,000	6,000	5,300	90
95	9,400	10,100	10,400	9,400	7,400	6,900	5,900	5,300	95
100	8,400	9,000	9,600	9,300	7,400	6,700	5,800	5,200	100
105	7,400	8,100	8,600	8,900	7,400	6,600	5,700	5,200	105
110	6,600	7,200	7,600	8,000	7,100	6,500	5,700	5,100	110
115	5,900	6,400	6,800	7,100	6,400	6,300	5,600	5,100	115
120	5,200	5,700	6,000	6,300	5,700	6,200	5,500	5,000	120
125	4,500	5,000	5,300	5,600	5,100	5,800	5,400	5,000	125
130	4,000	4,400	4,700	4,900	4,500	5,200	5,300	4,900	130
135	3,500	3,800	4,100	4,300	4,000	4,600	5,200	4,900	135
140	3,000	3,300	3,600	3,700	3,500	4,100	4,600	4,800	140
145	2,500	2,900	3,100	3,200	3,000	3,600	4,100	4,400	145
150	2,100	2,400	2,600	2,700	2,600	3,100	3,600	3,900	150
155	1,700	2,000	2,200		2,200	2,700	3,100	3,400	155
160	1,400	1,600	1,800		1,900	2,300	2,700	2,900	160
165	1,100	1,300	1,400		1,500	2,000	2,300	2,500	165
170		900	1,000		1,200	1,600	1,900	2,000	170
175					900	1,300	1,500	1,600	175
180						1,000	1,200		180
185							900		185

This information is not for crane operation. Operator must refer to the in-cab information for crane operation. Rated lifting capacities shown on fully extended outriggers do not exceed 85% of the tipping loads and on tires do not exceed 75% of the tipping loads.

28,800 lb Counterweight – Fully Extended Outriggers – 360° Rotation
 (All Capacities Are Listed In Pounds)

164.1 ft Main Boom Length

Radius (ft)	74 ft Manual Offset Fly				90 ft Manual Offset Fly				Radius (ft)
	0°	15°	30°	45°	0°	15°	30°	45°	
20									20
25									25
30									30
35									35
40									40
45									45
50									50
55	5,300								55
60	5,300				4,000				60
65	5,300				4,000				65
70	5,300	5,400			4,000				70
75	5,300	5,200			4,000				75
80	5,300	5,100			4,000	4,200			80
85	5,300	5,000	4,400		4,000	4,100			85
90	5,300	4,900	4,300		4,000	4,000			90
95	5,300	4,700	4,200	3,900	4,000	3,800	3,500		95
100	5,300	4,600	4,100	3,800	4,000	3,700	3,400	3,200	100
105	5,200	4,500	4,000	3,700	4,000	3,600	3,300	3,100	105
110	5,100	4,400	4,000	3,700	4,000	3,500	3,200	3,100	110
115	5,000	4,300	3,900	3,600	3,800	3,400	3,100	3,000	115
120	4,800	4,200	3,800	3,500	3,700	3,300	3,100	2,900	120
125	4,700	4,100	3,700	3,500	3,600	3,200	3,000	2,800	125
130	4,400	4,000	3,600	3,400	3,500	3,100	2,900	2,700	130
135	3,800	3,900	3,600	3,400	3,400	3,000	2,800	2,700	135
140	3,400	3,800	3,500	3,300	3,300	3,000	2,700	2,600	140
145	2,900	3,500	3,400	3,300	2,900	2,900	2,700	2,500	145
150	2,500	3,100	3,400	3,200	2,500	2,800	2,600	2,500	150
155	2,100	2,600	3,100	3,200	2,100	2,700	2,500	2,400	155
160	1,700	2,300	2,700	2,900	1,700	2,300	2,500	2,400	160
165	1,400	1,900	2,300	2,500	1,400	1,900	2,300	2,300	165
170	1,100	1,500	1,900	2,100	1,100	1,600	1,900	2,200	170
175		1,200	1,500	1,700		1,200	1,600	1,800	175
180		900	1,200	1,300		900	1,300	1,400	180
185			900	1,000			900	1,100	185
190									190
195									195

This information is not for crane operation. Operator must refer to the in-cab information for crane operation. Rated lifting capacities shown on fully extended outriggers do not exceed 85% of the tipping loads and on tires do not exceed 75% of the tipping loads.

Main Boom Lift Capacity Charts – On Tires

28,800 lb Counterweight – On Tires – Stationary – Boom Centered Over Front Between Tire Tracks (All Capacities Are Listed In Pounds)									
Radius (ft)	Boom Length (ft)							Radius (ft)	
	38.3	50	61.7	75	86	100.0	111.2		125
12	66,300								12
15	55,700	58,400							15
20	43,300	46,200	42,100						20
25	34,700	37,600	36,800	40,000					25
30	28,200	31,300	32,700	33,900	31,100				30
35		26,100	28,100	29,000	28,000	24,000			35
40		20,600	22,600	23,500	24,000	24,000	19,900		40
45			18,500	19,500	20,000	20,000	19,900		45
50			15,400	16,300	16,800	16,900	16,800	16,400	50
55				13,900	14,400	14,500	14,500	14,100	55
60				11,900	12,400	12,500	12,500	12,100	60
65				10,200	10,700	10,800	10,900	10,500	65
70					9,300	9,400	9,500	9,100	70
75					8,100	8,200	8,300	7,900	75
80						7,200	7,200	6,900	80
85						6,300	6,300	6,000	85
90						5,500	5,500	5,200	90
95							4,800	4,500	95
100							4,200	3,900	100
105								3,300	105
110								2,800	110
115								2,400	115

This information is not for crane operation. Operator must refer to the in-cab information for crane operation. Rated lifting capacities shown on fully extended outriggers do not exceed 85% of the tipping loads and on tires do not exceed 75% of the tipping loads.

28,800 lb Counterweight – On Tires – Pick & Carry (Creep) – Boom Centered Over Front
 (All Capacities Are Listed In Pounds)

Radius (ft)	Boom Length (ft)								Radius (ft)
	38.3	50	61.7	75	86	100	111.2	125	
12	59,600								12
15	49,400	51,900							15
20	37,500	40,200	41,700						20
25	29,200	31,900	33,600	34,400					25
30	23,000	26,000	27,700	28,600	29,000				30
35		21,400	23,100	24,000	24,500	21,000			35
40		17,700	19,500	20,400	20,900	21,000	18,100		40
45			16,600	17,500	18,000	18,100	18,100		45
50			14,200	15,200	15,700	15,800	15,800	15,500	50
55				13,200	13,700	13,800	13,900	13,500	55
60				11,500	12,000	12,100	12,200	11,800	60
65				10,000	10,500	10,600	10,700	10,400	65
70					9,300	9,400	9,400	9,100	70
75					8,100	8,200	8,300	7,900	75
80						7,200	7,200	6,900	80
85						6,300	6,300	6,000	85
90						5,500	5,500	5,200	90
95							4,800	4,500	95
100							4,200	3,900	100
105								3,300	105
110								2,800	110
115								2,300	115

This information is not for crane operation. Operator must refer to the in-cab information for crane operation. Rated lifting capacities shown on fully extended outriggers do not exceed 85% of the tipping loads and on tires do not exceed 75% of the tipping loads.

28,800 lb Counterweight – On Tires – Pick & Carry (2.5 mph) – Boom Centered Over Front
(All Capacities Are Listed In Pounds)

Radius (ft)	Boom Length (ft)								Radius (ft)
	38.3	50	61.7	75	86	100	111.2	125	
12	49,700								12
15	41,000	43,400							15
20	30,500	33,200	34,800						20
25	23,300	26,100	27,800	28,600					25
30	17,900	20,900	22,600	23,500	24,000				30
35		16,900	18,600	19,500	20,000	20,100			35
40		13,700	15,600	16,400	16,900	17,000	17,000		40
45			13,000	14,000	14,500	14,600	14,600		45
50			10,900	11,900	12,400	12,500	12,600	12,200	50
55				10,100	10,700	10,800	10,800	10,500	55
60				8,600	9,200	9,300	9,400	9,000	60
65				7,400	7,900	8,000	8,100	7,700	65
70					6,800	6,900	7,000	6,600	70
75					5,800	5,900	6,000	5,600	75
80						5,100	5,100	4,800	80
85						4,300	4,400	4,000	85
90						3,600	3,700	3,300	90
95							3,100	2,700	95
100							2,500	2,100	100
105								1,600	105
110								1,200	110

This information is not for crane operation. Operator must refer to the in-cab information for crane operation. Rated lifting capacities shown on fully extended outriggers do not exceed 85% of the tipping loads and on tires do not exceed 75% of the tipping loads.

Main Boom Lift Capacity Charts – 85% – Metric

13.2t Counterweight – Fully Extended Outriggers – 360° Rotation (All Capacities Are Listed In Kilograms)												
Radius (m)	Boom Length (m)											Radius (m)
	11.67	15.24–15.38	18.80–19.21	22.78–23.18	26.21–27.28	30.48	33.88–34.94	38.1	41.82–42.75	45.72	50.02	
2.1	110 000**											2.1
2.5	90 000*											2.5
3.0	85 000*											3.0
3.0	74 650	73 350	62 400									3.0
3.5	68 100	68 200	62 400									3.5
4.0	62 450	63 200	60 400	54 600								4.0
4.5	57 650	58 400	57 100	54 600	41 650							4.5
5.0	51 950	53 200	53 550	53 350	41 650							5.0
6.0	42 550	43 800	44 200	44 100	41 650	29 950	22 950					6.0
7.0	35 700	37 000	37 400	37 350	36 900	29 950	22 950					7.0
8.0	30 500	31 800	32 250	32 200	31 850	29 950	22 950	17 650	11 600			8.0
9.0	26 400	27 750	28 200	28 300	28 750	28 400	22 950	17 650	14 050	10 250		9.0
10.0		24 450	24 900	25 600	25 450	25 100	22 050	17 650	14 050	10 250		10.0
12.0		19 650	20 450	20 700	20 550	20 200	19 200	17 500	14 050	10 250	8 950	12.0
14.0			16 250	16 450	16 250	15 950	15 400	15 700	14 050	10 250	8 950	14.0
16.0			12 900	13 150	13 150	13 100	12 950	12 650	12 300	10 250	8 950	16.0
18.0				10 750	10 850	10 700	10 550	10 400	10 550	10 250	8 950	18.0
20.0				9 150	9 050	8 900	8 750	9 450	9 300	8 950	8 650	20.0
22.0					7 650	7 950	8 000	8 000	7 850	7 550	7 250	22.0
24.0					6 500	7 150	7 150	6 950	6 800	6 500	6 200	24.0
26.0						6 200	6 200	6 000	5 850	5 550	5 300	26.0
28.0							5 400	5 400	5 200	5 100	4 800	28.0
30.0								4 750	4 550	4 400	4 150	30.0
32.0								3 350	4 000	3 850	3 550	32.0
34.0									3 500	3 350	3 100	34.0
36.0										2 950	2 650	36.0
38.0										2 550	2 300	38.0
40.0										1 250	1 950	40.0
42.0											1 650	42.0
44.0												44.0
46.0											900	46.0

* Over Front Only With Special Reeving And/Or Special Equipment
 ** Over Front Only With Special Reeving And/Or Special Equipment On Intermediate Outriggers

This information is not for crane operation. Operator must refer to the in-cab information for crane operation. Rated lifting capacities shown on fully extended outriggers do not exceed 85% of the tipping loads and on tires do not exceed 75% of the tipping loads.

Fly Attachment Lift Capacity Charts – Optional

13.2t Counterweight – Fully Extended Outriggers – 360° Rotation									
50.02m Main Boom Length									
Radius (m)	10.7m Manual Offset Fly				17.7m Manual Offset Fly				Radius (m)
	0°	15°	30°	45°	0°	15°	30°	45°	
12.0	4 950								12.0
14.0	4 950								14.0
16.0	4 950				3 350				16.0
18.0	4 950	5 200			3 350				18.0
20.0	4 950	5 200	5 150		3 350	3 500			20.0
22.0	4 950	5 200	5 050	4 550	3 350	3 400			22.0
24.0	4 950	5 200	5 000	4 500	3 350	3 300			24.0
26.0	4 950	5 200	4 900	4 400	3 350	3 250	2 800		26.0
28.0	4 600	4 950	4 750	4 300	3 350	3 150	2 700	2 400	28.0
30.0	3 950	4 250	4 500	4 250	3 350	3 050	2 650	2 350	30.0
32.0	3 350	3 650	3 900	4 050	3 350	3 000	2 600	2 350	32.0
34.0	2 900	3 150	3 350	3 500	3 150	2 900	2 550	2 300	34.0
36.0	2 450	2 700	2 850	3 000	2 700	2 850	2 500	2 300	36.0
38.0	2 100	2 300	2 450	2 550	2 300	2 650	2 450	2 250	38.0
40.0	1 750	1 900	2 050	2 150	1 950	2 300	2 400	2 200	40.0
42.0	1 450	1 600	1 750	1 800	1 650	1 950	2 200	2 200	42.0
44.0	1 150	1 300	1 450	1 500	1 400	1 650	1 900	2 000	44.0
46.0	950	1 050	1 150	1 200	1 150	1 400	1 600	1 700	46.0
48.0	700	800	900		900	1 150	1 300	1 400	48.0
50.0	500	600	650		700	900	1 050	1 150	50.0
52.0		400	450		550	700	850	900	52.0
54.0						500	650	650	54.0
56.0							450		56.0

This information is not for crane operation. Operator must refer to the in-cab information for crane operation. Rated lifting capacities shown on fully extended outriggers do not exceed 85% of the tipping loads and on tires do not exceed 75% of the tipping loads.

13.2t Counterweight – Fully Extended Outriggers – 360° Rotation
(All Capacities Are Listed In Pounds)

50.02m Main Boom Length

Radius (m)	22.6m Manual Offset Fly				27.4m Manual Offset Fly				Radius (m)
	0°	15°	30°	45°	0°	15°	30°	45°	
16.0	2 400								16.0
18.0	2 400								18.0
20.0	2 400				1 800				20.0
22.0	2 400	2 400			1 800				22.0
24.0	2 400	2 350			1 800	1 900			24.0
26.0	2 400	2 250	2 000		1 800	1 850			26.0
28.0	2 400	2 200	1 950		1 800	1 750	1 650		28.0
30.0	2 400	2 100	1 900	1 750	1 800	1 700	1 550	1 500	30.0
32.0	2 350	2 050	1 850	1 700	1 800	1 650	1 500	1 400	32.0
34.0	2 300	2 000	1 800	1 650	1 800	1 600	1 450	1 350	34.0
36.0	2 200	1 900	1 750	1 600	1 700	1 500	1 400	1 300	36.0
38.0	2 150	1 850	1 700	1 550	1 650	1 450	1 350	1 300	38.0
40.0	1 900	1 800	1 650	1 550	1 600	1 400	1 300	1 250	40.0
42.0	1 600	1 750	1 600	1 500	1 500	1 350	1 250	1 200	42.0
44.0	1 350	1 650	1 550	1 500	1 350	1 300	1 200	1 150	44.0
46.0	1 100	1 350	1 500	1 450	1 100	1 250	1 150	1 100	46.0
48.0	850	1 100	1 300	1 400	850	1 100	1 150	1 100	48.0
50.0	650	900	1 050	1 150	650	900	1 100	1 050	50.0
52.0	450	650	850	900	450	700	850	950	52.0
54.0		500	600	700		500	650	750	54.0
56.0			400	450			450	550	56.0

This information is not for crane operation. Operator must refer to the in-cab information for crane operation. Rated lifting capacities shown on fully extended outriggers do not exceed 85% of the tipping loads and on tires do not exceed 75% of the tipping loads.

Main Boom Lift Capacity Charts – On Tires

13.2t lb Counterweight – On Tires – Stationary – Boom Centered Over Front Between Tire Tracks (All Capacities Are Listed In Kilograms)									
Radius (m)	Boom Length (m)							Radius (m)	
	11.67	15.24	18.8	22.86	26.21	30.48	33.88		38.1
3.5	30 050								3.5
4.0	28 100								4.0
4.5	25 600	26 450							4.5
5.0	23 400	24 700							5.0
6.0	19 900	21 250	19 050						6.0
7.0	17 150	18 500	17 600						7.0
8.0	14 900	16 250	16 150	17 450					8.0
9.0	13 050	14 450	15 000	15 600	14 050				9.0
10.0		12 900	13 700	14 150	13 300				10.0
12.0		9 600	10 500	10 950	11 150	10 850	9 000		12.0
14.0			8 100	8 500	8 750	8 750	8 750		14.0
16.0			6 400	6 850	7 100	7 100	7 100	6 950	16.0
18.0				5 550	5 800	5 800	5 850	5 650	18.0
20.0				4 550	4 750	4 800	4 850	4 700	20.0
22.0					4 000	4 000	4 050	3 900	22.0
24.0						3 350	3 400	3 250	24.0
26.0							2 800	2 700	26.0
28.0							2 350	2 250	28.0
30.0								2 000	30.0
32.0									32.0
34.0									34.0

This information is not for crane operation. Operator must refer to the in-cab information for crane operation. Rated lifting capacities shown on fully extended outriggers do not exceed 85% of the tipping loads and on tires do not exceed 75% of the tipping loads.

13.2t Counterweight – On Tires – Pick & Carry (Creep) – Boom Centered Over Front (All Capacities Are Listed In Kilograms)									
Radius (m)	Boom Length (m)								Radius (m)
	11.67	15.24	18.8	22.86	26.21	30.48	33.88	38.1	
3.5	27 000								3.5
4.0	25 150								4.0
4.5	22 750	23 500							4.5
5.0	20 700	21 800							5.0
6.0	17 300	18 500	18 900						6.0
7.0	14 600	15 850	16 600						7.0
8.0	12 450	13 750	14 500	13 150					8.0
9.0	10 650	12 000	12 800	13 150	13 400				9.0
10.0		10 550	11 350	11 750	11 950				10.0
12.0		8 200	9 050	9 450	9 700	9 500	8 200		12.0
14.0			7 300	7 700	7 950	8 000	8 000		14.0
16.0			6 000	6 400	6 650	6 700	6 700	6 550	16.0
18.0				5 350	5 600	5 650	5 650	5 500	18.0
20.0				4 450	4 700	4 750	4 750	4 600	20.0
22.0					3 950	4 000	4 050	3 900	22.0
24.0					3 350	3 350	3 400	3 250	24.0
26.0						2 800	2 850	2 700	26.0
28.0						2 350	2 400	2 250	28.0
30.0							2 000	1 850	30.0
32.0								1 500	32.0
34.0								1 200	34.0

This information is not for crane operation. Operator must refer to the in-cab information for crane operation. Rated lifting capacities shown on fully extended outriggers do not exceed 85% of the tipping loads and on tires do not exceed 75% of the tipping loads.

13.2t Counterweight – On Tires – Pick & Carry 4 kph) – Boom Centered Over Front
 (All Capacities Are Listed In Kilograms)

Radius (m)	Boom Length (m)							Radius (m)	
	11.67	15.24	18.8	22.86	26.21	30.48	33.88		38.1
3.5	22 500								3.5
4.0	20 950								4.0
4.5	18 850	19 650							4.5
5.0	17 050	18 200							5.0
6.0	14 100	15 300	15 750						6.0
7.0	11 750	13 050	13 800						7.0
8.0	9 900	11 200	11 950	12 350					8.0
9.0	8 300	9 650	10 450	10 850	11 050				9.0
10.0		8 400	9 200	9 600	9 800				10.0
12.0		6 400	7 200	7 600	7 850	7 850	7 900		12.0
14.0			5 700	6 150	6 400	6 400	6 450		14.0
16.0			4 550	4 950	5 200	5 250	5 300	5 150	16.0
18.0				4 050	4 300	4 350	4 350	4 200	18.0
20.0				3 250	3 500	3 550	3 600	3 450	20.0
22.0					2 900	2 950	2 950	2 800	22.0
24.0					2 350	2 400	2 400	2 250	24.0
26.0						1 950	1 950	1 800	26.0
28.0						1 550	1 550	1 400	28.0
30.0							1 200	1 050	30.0
32.0								750	32.0

This information is not for crane operation. Operator must refer to the in-cab information for crane operation. Rated lifting capacities shown on fully extended outriggers do not exceed 85% of the tipping loads and on tires do not exceed 75% of the tipping loads.

This Page Intentionally Blank

This Page Intentionally Blank

Link-Belt Cranes Lexington, Kentucky www.linkbelt.com

®Link-Belt is a registered trademark. Copyright 2019. We are constantly improving our products and therefore reserve the right to change designs and specifications.